

StrapPack[®]

Automatic Strapping Machine

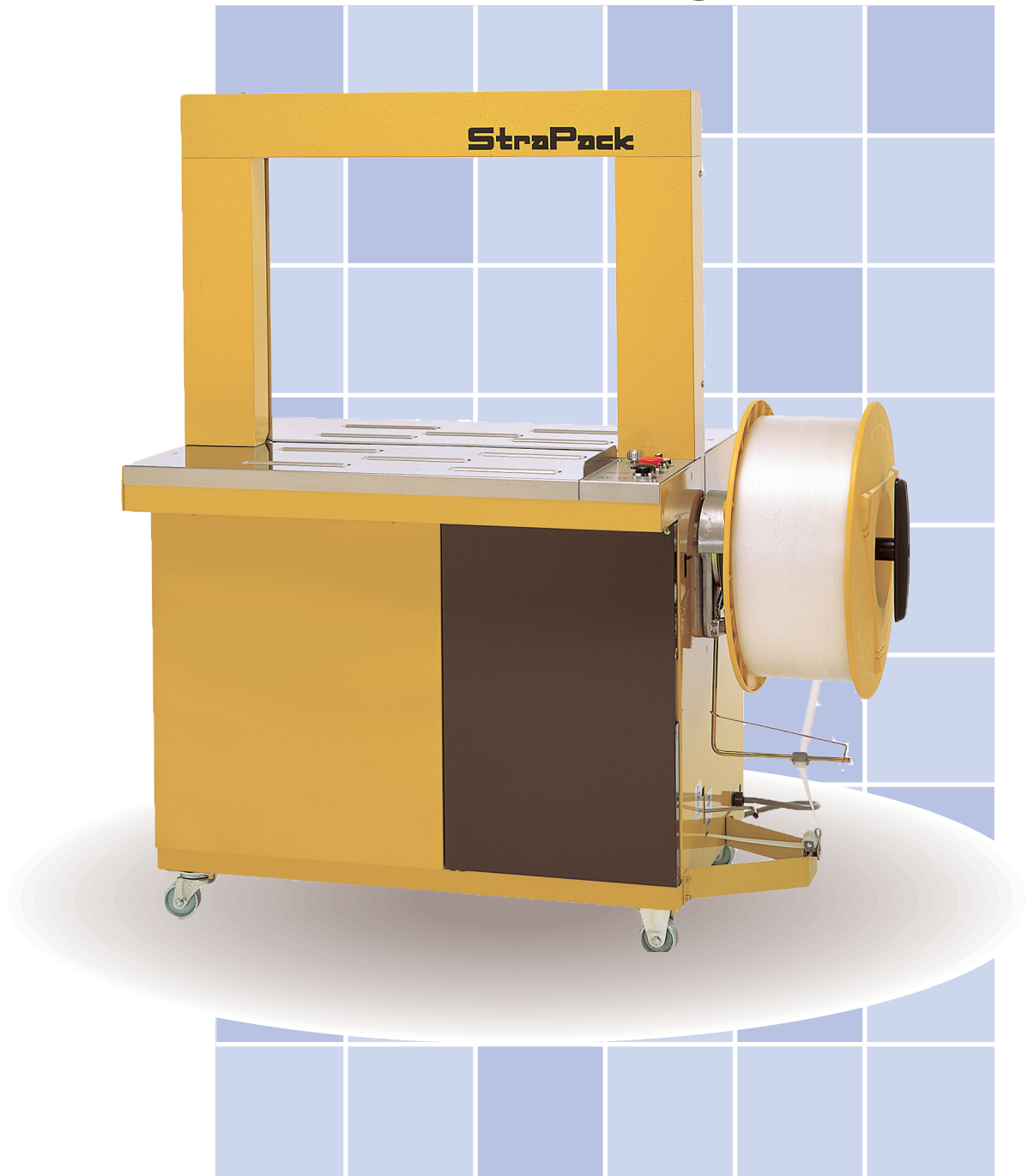

AQ-7

AQ-7



Automatic Strapping Machine

■ **HIGH SPEED — 2.2 SECONDS / CYCLE**
Minimum of 27 cycles per minute (depending on package size).

■ **ENERGY CONSERVATION**
Power supply is 200 / 220 / 240 / 380 / 400 / 415V, 3PH
Motors run only when necessary.

■ **QUICK WARM-UP HEATER**
Only 25 seconds required to reach operating temperature. Ready indicator lamp reduces wasted strap.

■ **OIL-FREE MECHANISM**
Sealing head never requires lubrication, saving service time and cleaning of components.

■ **EASY TENSION CONTROL**
Tension is adjustable via a conveniently positioned dial. Consistent tensioning from 0 to 70kg (80mm stroke) is provided by a tension arm system.

■ **COMPACT**
Machine body is small, light and easy to maneuver

■ **NEW ARCH SYSTEM**
Newly designed arch ensures more precise strap positioning and reduces strap twisting. Arch variations available.

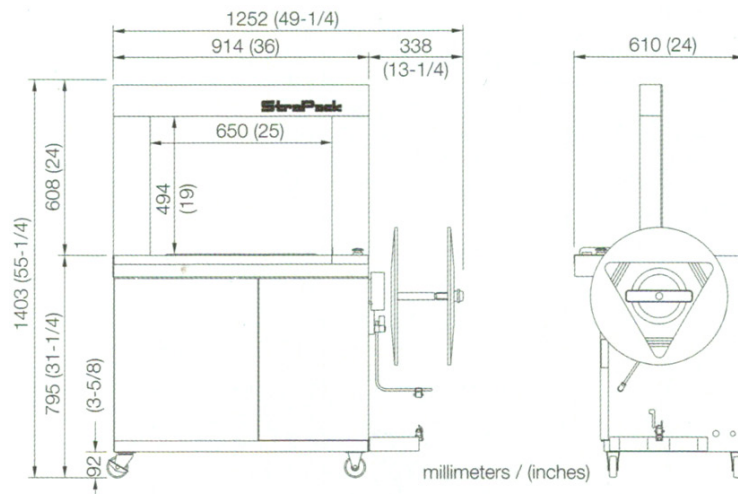

■ Standard Specifications

Dimension	Width	1252mm	49-1/4 in.
	Height	1403 mm	55-1/4 in.
	Depth	610 mm	24 in.
	Weight	180kg	396 lbs
TABLE HEIGHT		795 mm	31-5/16 in
Package Size	MAX :	W 620 × H 480 mm	W 24-1/2 × H 18-7/8 in
	MIN :	W 80 × H 30 mm	W 3-1/8 × H 1-1/4 in
JOINT/STRAP/COIL		heat seal / polypropylene / ID200 × OD450 × W200mm	
Strap Width		5,6,9, 12 mm (1/4,3/8,1/2 in.)	
Strap Tension		Max 784N (80kgf) (176lbs) 80mm (3-1/8 in) stroke	
Power Supply		200, 220, ,240,380.400,415 V 3 Phase 50 / 60 Hz 0.85 KVA	

Dimensions and specifications are subject to change without notice.
Modification rights reserved.

© 2016 Strapack Corporation

DISTRIBUTED BY:

STRAPACK CORPORATION

8-16-6, Ginza, Chuo-ku, Tokyo, 104-0061, JAPAN
Phone: 81-3-6278-1806 Fax: 81-3-6278-1807
(URL) <http://www.strapack.com> (E-mail) info@strapack.com

STRAPACK INC.

33508 Central Avenue, Union City, CA 94587-2097 U.S.A.
Phone 1-510-475-6000 Fax. 1-510-475-6090

STRAPACK, N.V./S.A.

Uilenbaan 200, B-2160 Wommelgem, BELGIUM
Phone 32-(0)3-355-1520 Fax. 32-(0)3-355-1521